

The Fiber Optic Association, Inc.

1-760-451-3655 Fax 1-781-207-2421

Email: info@foa.org <http://www.foa.org>

The Instructors' Guide To *The FOA Reference Guide To Premises Cabling*

This book was intended as a textbook for introducing students to premises cabling and/or training installers of premises cabling. It focuses on the practical aspects of designing, installing, testing and troubleshooting premises (building and campus) cable plants and networks.

This book has been created from current training programs and reference materials from instructors, standards organizations and vendors. The material comes from practical experience and the assistance of a large number of instructors, reviewers and vendors.

The timeliness of the material is important in a technology like communications cabling that is changing rapidly. New product innovation, updated standards and rapid cost reduction are the norm. We have tried to include the latest material as of our publishing date. It is always a good idea to read the appropriate trade magazines and contact the vendors of cabling products for the latest applications and product information. In addition, the FOA website (www.thefoa.org) and the FOA Online Reference Guide (www.foaguide.org) are sources of up to date information.

How, one might ask, can a "Fiber Optic Association" produce an unbiased book on premises cabling when so much of that cabling is copper and many users are migrating to wireless? Most cabling networks already depend on fiber optics for high speed backbones and new fiber optic cabling systems for premises applications are being introduced. The FOA is focused on education of technicians, not selling products, and we think it's important that every tech knows as much as possible about copper, fiber and wireless technology so they can deal successfully with all three in premises cabling and that is the philosophy behind the FOA CPCT certification.

You will note that this book includes some topics not generally covered in cabling books, like coax and wireless, and ignores others like legacy POTS (plain old telephone service) lines because of their relative (lack of) importance in today's world. We also do not obsess over standards, covering them only to ensure the technician knows their proper use.

The FOA created its Online Reference Guide (www.foaguide.org) to provide a more up-to-date and unbiased reference for those seeking information on cabling and fiber optic technology, components, applications and installation. It's success confirms the assumption that most users prefer the Internet for technical information. For those interested in premises cabling, copper, fiber or connections to wireless access points, the Premises Cabling Systems section of the online reference guide provides a wealth of usable information.

The textbook was updated in January 2018.

Description of Chapters In the Book

Chapter 1 Overview of Premises Cabling

Chapter 1 covers historically how communications and cabling developed and the role of cabling in communications. It covers how standards are developed and are used to ensure interoperability of cabling system components and systems using cabling. It also covers the important differences between standards and codes'

Chapter 2 Cabling Jargon

The key to understanding any technology is understanding the language of the technology – the jargon. This chapter covers an overview of cabling jargon to introduce the student to the language of premises cabling and help them understand what they will be reading in the book. Unlike a glossary (included in Appendix D), this chapter provides definitions, descriptions and illustrations of terms.

Chapter 3 Communications Networks and Applications

Chapter 3 covers computer networks use cabling for connections and the types of cabling used in those networks. Types of cabling, including unshielded twisted pair copper and optical fiber cabling and making the choice among copper, fiber and wireless connections are covered. Since premises cabling includes other types of systems and applications, those are described also.

Chapter 4 Copper cabling

Chapter 4 covers copper cabling types in premises cabling. Unshielded twisted pair (UTP) cable is the primary copper cable, so most of the material focuses on UTP. Covered are how UTP cable is used to transmit signals for communications, the grades of UTP cable, and installation practices for termination and testing. Also covered is how coax cable cable is used in premises cabling systems

Chapter 5 Fiber optics

Fiber optics is widely used in premises cabling as backbones, fiber to the desk and now in passive optical LANs. This chapter covers the types of fiber and cable used in premises applications, terminating and testing fiber optic cables. This chapter is condensed from the other FOA books and web pages, so there is plenty of additional materials available.

Chapter 6 Wireless

Wireless allows the user mobility - to roam unencumbered by cabling within the service area covered. Wireless uses radio frequency transmission to connect to the user - in effect replacing patchcords, allowing the final connection to be done over the radio link. This chapter covers the role of wireless in premises cabling systems, different types of wireless systems, why “wireless” is not “wireless” and options in installing wireless access points.

Chapter 7 Designing premises cabling networks

Before a cabling system can be installed, it must be properly designed. This chapter

covers how to choose the types of cabling needs, designing cabling as part of a building infrastructure, creating pathways and spaces to accommodate cabling and how to document a cabling installation. This chapter refers to industry standards in some detail (along with Appendix B) since those standards were written to ensure designs would meet performance specifications.

Chapter 8 Installation

After the design of a premises cabling network is completed, the next step is to install it. What do we mean by the “installation process?” It’s the process of physically installing and completing the network, turning the design into an operating system. This chapter covers what is involved in a premises cabling installation, the role of the contractor and installer, how to prepare for the installation, proper installation techniques for premises cabling, safety in cabling installation and removing and recycling abandoned cabling as required by new electrical codes.

Appendix A: KSAs for Premises Cabling

The ability to perform any job requires certain abilities, knowledge and skills, commonly referred to as “KSAs.” The FOA has developed this list to provide training organizations and instructors a list of topics that should be included in a basic training curriculum for CPCT certification.

Appendix B: Proposed Changes in TIA-568 Nomenclature

TIA has proposed changing the traditional names of many parts of a premises cabling network from traditional names derived from telephone systems to a more generic nomenclature.

Appendix C Fiber Optic Network Specifications

All copper premises cabling networks are designed around 100m links while fiber is specified according to the application. Included here are detailed specifications of fiber optic networks used in premises cabling that define fiber types, cable lengths and losses.

Appendix D Definitions of Terms

A glossary of terms used in communications and premises cabling.

Appendix E Additional Reference Materials

Where to find out more about cabling topics.

Answers to Chapter Quizzes

Chapter 1

Multiple Choice

Identify the choice that best completes the statement or answers the question.

- __B__ 1. 1. What is the standard everyone in the USA refers to as the basis of structured cabling?
- A. IEEE 802.3
 - B. EIA/TIA 568
 - C. EIA/TIA TR42
 - D. NEMA 63.1999
- __B__ 2. 2. What is the international standard for structured cabling?
- A. TIA-568
 - B. ISO-11801
 - C. ISO-9000
 - D. IEC-0001
- __C__ 3. 3. What copper cable types are included in the TIA-568 structured cabling standards?
- A. UTP (unshielded twisted pair), STP (shielded twisted pair) and coax
 - B. UTP (unshielded twisted pair) and coax
 - C. UTP (unshielded twisted pair), ScTP (screened twisted pair) and STP (shielded twisted pair)
 - D. Any communications cable
- __D__ 4. 4. What do Category 3, Category 5e and Category 6 designations mean?
- A. How well the cables are made
 - B. Flame retardance of the cable
 - C. How far the cable will work in networks
 - D. The performance level of UTP cable
- __A__ 5. 5. What is the cable from the telecom closet (room) to the work area called?
- A. Horizontal cabling
 - B. Backbone cabling
 - C. Work area cable
 - D. Patchcord
- __B__ 6. 6. What is the cabling from the telecom closet to the main cross connect or computer center called?
- A. Horizontal cabling
 - B. Backbone cabling

- C. Riser cable
- D. Patchcord

- B 7. Why is the structured cabling standard not like "code"?
- A. It doesn't deal with flammability
 - B. It is not legally required
 - C. It changes every year
 - D. It is not written by the NFPA
- D 8. What other cables are recognized in the structured cabling standards?
- A. CATV RG-6 coax
 - B. IBM Type II
 - C. Multimode fiber optic cable
 - D. Singlemode and multimode fiber optic cable
- A 9. What is the maximum length of a permanently installed UTP cabling link allowed in structured cabling standards?
- A. 90 meters
 - B. 100 meters
 - C. 100 feet
 - D. Depends on the electronics running on the link

Matching

Structured cabling architecture: Match the letter in the drawing with the definition below.

- E 10. Main cross connect
- D 11. Telecom closet (room)
- A 12. Backbone cabling
- B 13. Horizontal cabling
- F 14. Centralized fiber cabling
- C 15. Work area

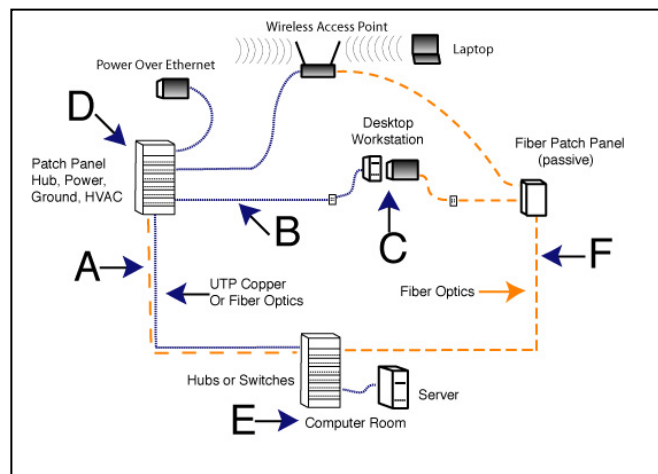

Chapter 2

True/False

Indicate whether the statement is true or false.

- T 1. Premises cabling refers to cabling used for communications inside a building or limited to a campus.
- F 2. Cabling standards are mandatory requirements for cables installed to meet building and electrical codes.
- T 3. UTP cable can be used to power many devices such as VoIP phones and low speed wireless access points.
- T 4. Fiber optic testing is easier than copper testing since only loss needs testing for premises cabling.

Multiple Choice

Identify the choice that best completes the statement or answers the question.

- B 5. 1. _____ is the standard which forms the basis of structured cabling in the US?
A. IEEE 802.3
B. EIA/TIA 568
C. EIA/TIA TR42
D. NEMA 63.1999
- B 6. The international standard for structured cabling is _____?
A. TIA-568
B. ISO-11801
C. ISO-9000
D. IEC-0001
- D 7. What cable types are included in the TIA-568 structured cabling standards?
A. UTP (unshielded twisted pair), STP (shielded twisted pair) and coax
B. UTP (unshielded twisted pair) and coax
C. UTP (unshielded twisted pair), ScTP (screened twisted pair) and STP (shielded twisted pair)
D. UTP (unshielded twisted pair), ScTP (screened twisted pair), STP (shielded twisted pair) and fiber optics
- D 8. What do category ratings of UTP cable (e.g. Cat 3, Cat 5e, Cat 6 and Cat 6A) mean?
A. How well the cables are made
B. Flame retardance of the cable
C. How far the cable will work in networks

D. The performance level of UTP cable

__A__

9. What is the cable from the telecom room (closet) to the work area called?

- A. Horizontal cabling
- B. Backbone cabling
- C. Work area cable
- D. Patchcord

__A__

10. What is the installed cable plant from work area outlet jack to the patch panel in the telecom closet called?

- A. Permanent link
- B. Channel
- C. Link cable
- D. Patchcord

__A__

11. Why is the structured cabling standard not like "code"?

- A. It's voluntary, not required by law
- B. It doesn't deal with flammability
- C. It changes every year
- D. It is not written by the NFPA

__4__

12. A category-rated UTP cable (Cat 3/5e/6/6A) used for horizontal cabling has _____ color coded pairs of wires.

- A. 2
- B. 4
- C. 25
- D. Any even number

Chapter 3

True/False

Indicate whether the statement is true or false.

- T 1. If the network does not require high bandwidth, it can share the 4 pairs in a UTP cable to transmit 2 Ethernet signals or one Ethernet and one voice line,

Multiple Choice

Identify the choice that best completes the statement or answers the question.

- A 2. Ethernet was first developed as a _____ architecture using _____ cable with _____.
- A. Bus, coax, taps
 - B. Bus, UTP, RJ-45 connectors
 - C. Star, UTP, RJ-45 connectors
 - D. Ring, coax, RJ-45 connectors

- C 3. The development of _____ provided a low cost cabling alternative for networks.
- A. CATV coax
 - B. IBM Type 1 cable
 - C. Balanced transmission on UTP cabling
 - D. Ethernet

- C 4. FDDI and Token Ring networks used a _____ architecture.
- A. Bus
 - B. Star
 - C. Ring
 - D. Balanced

- B 5. Ethernet changed from a _____ to _____ network architecture when it switched to UTP cable.
- A. Bus, ring
 - B. Bus, star
 - C. Ring, coax
 - D. Ring, UTP

- A 6. Even _____ require cabling connections in a network.
- A. Wireless access points
 - B. Mobile phones
 - C. Laptop computers
 - D. Blackberries

- B 7. Until Gigabit Ethernet, LANs only used _____ pairs of the UTP cable.
- A. 1
 - B. 2
 - C. 3

D. 4

__D__

8. Gigabit Ethernet uses all four pairs of a UTP cable _____.

- A. For power
- B. With 2 pairs in each direction
- C. Bidirectionally
- D. Simultaneously and bidirectionally

__B__

9. Hardware like video cameras designed to run on coax can be used on UTP with a converter device called a _____.

- A. Splitter
- B. Balun
- C. Adapter
- D. TOSLINK

Chapter 4

Multiple Choice

Identify the choice that best completes the statement or answers the question.

- __A__ 1. What do UTP Category 3, Category 5e and Category 6 designations indicate?
- A. The frequency performance grade of the cable
 - B. UL-rated Flame retardance of the cable
 - C. How far the cable will work in networks
 - D. They are trade names for cable types
- __B__ 2. What minimum level of UTP cable type is required by 1000Base-T (Gigabit Ethernet)?
- A. Cat 5
 - B. Cat 5e
 - C. Cat 6
 - D. Augmented Cat 6
- __C__ 3. What is the main characteristic of unshielded twisted pair Category 5e or Category 6 cable that gives it high frequency performance?
- A. High performance plastics in the insulation of the pairs
 - B. The size of the conductors
 - C. The rate of twists in the pairs of wires
 - D. The connectors
- __C__ 4. Category 6A cable is specified and must be tested during certification to ___ MHz.
- A. 100
 - B. 250
 - C. 500
 - D. 1000
- __C__ 5. The name for the latest generation Cat 6 UTP cable for use with 10 Gigabit networks is _____.
- A. Enhanced Cat 6
 - B. Extended Cat 6
 - C. Augmented Cat 6
 - D. Cat 7
- __A__ 6. If you use an Cat 3 UTP jack on newer Cat 5e cable plant, the link performance will meet _____ specs.
- A. Cat 3
 - B. Cat 5
 - C. Cat 5E
 - D. Cat 6

- __B__ 7. Before UTP cabling became widely used and the industry standard, most Ethernet Networks were connected over _____ cable.
- A. Copper
 - B. Coaxial
 - C. Shielded
 - D. Telephone
- __C__ 8. Standard UTP (unshielded twisted pair) copper cabling for voice and data installations has how many pairs of wire?
- A. Two
 - B. Three
 - C. Four
 - D. Twenty-five
- __B__ 9. Attenuation in copper cable _____.
- A. Is lower at higher frequencies
 - B. Is higher at higher frequencies
 - C. Is the same at all frequencies
 - D. Is highest at 10 MHz
- __A__ 10. When terminating Cat 5e/6, what must be remembered to maintain the performance of the installed cable?
- A. Keep the pairs twisted to within 1/2 inch of the termination
 - B. Do not strip insulation off the wires
 - C. The jacket of the cable must not be stripped back more than 3 inches
 - D. The punchdown tool must cut off the wires close to the end
- __B__ 11. Why are punchdown blocks used with Cat 3 and Cat 5 cabling?
- A. Terminate cables from equipment
 - B. Interconnect cables in a telecom closet
 - C. Change from T568A to T568B terminations
 - D. Meet EIA/TIA 568 Standards
- __C__ 12. Which punchdown block is more often used with data (Cat 5e/6)?
- A. Bix block
 - B. Krone block
 - C. 110 block
 - D. 66 block
- __D__ 13. Which punchdown block is more often used with POTS telephone connections?
- A. Bix block
 - B. Krone block
 - C. 110 block
 - D. 66 block
- __B__ 14. What kinds of connection to the cable does a UTP jack typically have?

- A. 66 punchdown
- B. 110 punchdown
- C. Snap-in contacts
- D. Solder connections

__A__

15. Does a jack have the same color code for the pairs as a punchdown block?

- A. No
- B. Yes
- C. Depends on the type and manufacturer of the jack
- D. Depends on whether it is T568A, T568B or USOC

__A__

16. The Cat 3 jack is the same as a Cat 5e/6 jack except _____.

- A. There are no internal twists to enhance performance
- B. The punchdowns fit bigger wires
- C. It only connects to RJ-45 plugs
- D. It is keyed to snap into outlets upside down

__C__

17. What is a RJ-45 connector?

- A. The connector used only with Cat 5e/6 jacks
- B. A special high frequency connector
- C. A modular 8 pin connector with USOC pinout
- D. A trade name

__C__

18. The difference between the termination schemes of T568A and T568B is _____?

- A. Keying on plugs and jacks
- B. Reversal of tip and ring
- C. Reversal of pairs 2 and 3
- D. Determined by the speed of the network

__A__

19. What is a "certified" UTP cable?

- A. Cable tested to EIA/TIA 568 specifications
- B. Cable tested by an automated tester
- C. Cable tested to both Cat 3 and Cat 5 specifications
- D. Cable tested to "enhanced Cat 5" or "augmented Cat 6" specifications

__C__

20. What instrument measures the length of a cable?

- A. Network analyzer
- B. Wiremapper
- C. Time domain reflectometer (TDR)
- D. All of the above

__B__

21. Why is "Powersum NEXT" important in new cable plants?

- A. Higher speed networks need less crosstalk
- B. New networks have signals on all the pairs in the cable
- C. Cat 5e and Cat 6 cable are more sensitive to crosstalk
- D. It's a marketing issue, not a technical issue

- ___A___ 22. What is included in a channel test that is not included in a permanent link test?
- A. Patchcords on either end of the link
 - B. Extra attenuation from the connections at the ends
 - C. Longer cable lengths
 - D. Performance of the networking equipment
- ___B___ 23. What is the most likely cause of crossed pairs?
- A. Misreading color codes on a Cat 3 jack
 - B. Terminating one end as T568A and the other as T568B
 - C. Using a Cat 3 jack on one end and a Cat 5e/6 jack on the other
 - D. Termination of the jack using the BLOGBr color code sequence
- ___B___ 24. Voice grade unshielded twisted pair cables (UTP) which are only intended to carry POTS (plain old telephone service) only need testing for_____.
- A. Shorts and opens
 - B. Wiremap
 - C. Crossed pairs
 - D. Crosstalk
- ___C___ 25. Of the three copper testers, (wiremappers, certification and the new validation testers), which actually tests the cable for real networks like Ethernet?
- A. Wiremapper
 - B. Certification tester
 - C. Validation tester
 - D. None of them

Chapter 5

Multiple Choice

Identify the choice that best completes the statement or answers the question.

- __B__ 1. Prior to cable plant acceptance or system turn-up, standards require that a(n) _____ is used to test the cable plant to ensure it is within the loss budget.
- A. Power meter
 - B. LSPM or OLTS (Light source and power meter, optical loss test set)
 - C. OTDR
 - D. All of the above
- __A__ 2. In an industrial environment, fiber is most often used to_____.
- A. Immunity to electrical noise prevents interference
 - B. Provide ultra-high speed connections to machines
 - C. Withstand high temperatures
 - D. Tolerate physical abuse
- __B__ 3. Which of the following are not necessary in a centralized fiber optic cabling architecture per industry standards?
- A. Repeaters or hubs
 - B. Telecom closets
 - C. Wall outlets
 - D. NIC cards
- __C__ 4. An older fiber design with a 50/125 micron core is now being used in cabling systems because it_____.
- A. Can be cabled in more compact cable designs
 - B. Costs half as much as other multimode fibers
 - C. Has a higher bandwidth with laser sources which gives more distance capability with gigabit (and above) networks
 - D. Excess supplies are currently available from the far east
- __A__ 5. In a multimode optical fiber, light signals travel in the _____ of the fiber.
- A. Core
 - B. Cladding
 - C. Both the core and cladding
 - D. Jacket
- __D__ 6. Which cable is used in most outdoor applications?
- A. Simplex
 - B. Distribution
 - C. Breakout
 - D. Loose Tube

__D__

7. Which connector was chosen as the standard for the most recent EIA/TIA 568 cabling standard?

- A. SC
- B. ST
- C. LC
- D. Any connector with a FOCIS document

__C__

8. Joining of two cables in a premises cable plant run is almost always done by _____.

- A. Mechanical splicing
- B. Fusion splicing
- C. Field installation of connectors
- D. Splicing on pigtailed connectors

__D__

9. Which multimode insertion loss test reference method is required in industry standards?

- A. OFSTP-14
- B. FOTP-34
- C. FOTP-171
- D. Any method as long as it is documented

__A__

10. For testing a terminated fiber optic cable or a patchcord, the instrument(s) you need is (are):

- A. FO power meter and light source or OLTS (optical loss test set)
- B. Visual Fault Locator
- C. Optical Continuous Wave Reflectometer
- D. Optical Time Domain Reflectometer

Matching

Identify the three basic components of an optical fiber:

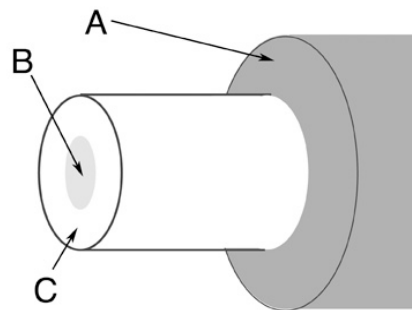

__B__

11. Core

__C__

12. Cladding

__A__

13. Primary Buffer Coating

Chapter 6

True/False

Indicate whether the statement is true or false.

- T 1. The single most important part of a wireless installation is proper placement of access points to insure proper coverage.
- T 2. Practically anyone with a laptop and wireless card can access any wireless network unless security is carefully programmed.

Multiple Choice

Identify the choice that best completes the statement or answers the question.

- A 3. Wireless networks are really used to replace _____.
A. The patchcord that connects a PC to a wall outlet connection
B. Backbone cabling
C. Structured cabling
D. Routers
- B 4. The common IEEE 802.11b wireless LAN is also called
A. Bluetooth
B. WiFi
C. WiMax
D. Hot Spot
- D 5. A wireless antenna is also known as a _____.
A. Hot spot
B. Wireless router
C. WC (wireless cell)
D. Access point
- C 6. Most wireless antennas connect to the Internet by _____.
A. RF wireless
B. RG-59 Coax
C. Structured cabling (Cat 5e or fiber)
D. STP cabling
- C 7. IEEE 802.11b has a range of ____ feet.
A. 33
B. 150
C. 300
D. 1000
- D 8. Before beginning a wireless installation, it is most important that you _____.
A. Decide which vendors to use
B. Make sure the vendors, products work together

- C. Carefully estimate costs
- D. Do a thorough site survey

__C__ 9. Wireless access points can use _____ to simplify powering the equipment.

- A. Low voltage power supplies
- B. AC
- C. Power over Ethernet (IEEE 802.3ah)
- D. Data signal power

__D__ 10. Potential sources of interference for wireless LANs include _____.

- A. Other wireless networks
- B. Remote controls like door openers
- C. Moving objects
- D. All of the above

Chapter 7

Multiple Choice

Identify the choice that best completes the statement or answers the question.

- B 1. Structured cabling standards call for a maximum length of UTP cable for data of _____.
- A. 90 meters
 - B. 100 meters
 - C. 300 meters
 - D. 800 meters
- A 2. Structured cabling standards allow for a maximum length of permanently installed (not including patchcords) UTP cable for data of _____.
- A. 90 meters
 - B. 100 meters
 - C. 300 meters
 - D. 800 meters
- A 3. UTP cable installed above the ceiling can _____ the ceiling tiles.
- A. not be laid on
 - B. be hung from frames of
 - C. be laid directly on top of
 - D. must be sleeved to be laid on top of
- B 4. UTP cable installed above the ceiling in hot climates may not _____.
- A. Meet crosstalk specs
 - B. Pass certification tests
 - C. Be fire safe
 - D. Support full standard link distances
- D 5. Structured cabling standards call for a maximum length of UTP cable for voice (POTS) of _____.
- A. 90 meters
 - B. 100 meters
 - C. 300 meters
 - D. 800 meters
- C 6. Structured cabling standards call for a maximum length of singlemode fiber optic cable for backbones of _____.
- A. 800 meters
 - B. 1000 meters
 - C. 3000 meters
 - D. 2000 meters

- __D__ 7. Structured cabling standards call for a maximum length of multimode fiber optic cable for backbones of _____.
- A. 800 meters
 - B. 1000 meters
 - C. 3000 meters
 - D. 2000 meters
- __B__ 8. For planning office layout, each user should be allocated _____ floor space.
- A. Adequate
 - B. 100 sq ft
 - C. 3 sq m
 - D. shared
- __D__ 9. Each floor should be allocated one _____ when floor space is under 10,000 sq ft.
- A. Equipment room
 - B. MUTOA
 - C. User
 - D. Telcom room (closet)
- __D__ 10. Both equipment rooms and telecom rooms should have _____.
- A. Uninterruptible power
 - B. Air conditioning
 - C. Data quality ground
 - D. All of the above
- __D__ 11. One cannot emphasize strongly enough the value of _____.
- A. Standards
 - B. Cabling
 - C. Fiber optics
 - D. Documentation

Chapter 8

True/False

Indicate whether the statement is true or false.

- T 1. Riser cables are more easily installed by dropping cables down than pulling them up.
- T 2. Power cables are a safety hazard because so many installations involve working in areas with many power cables.
- F 3. The NEC does not refer to UTP or fiber cables because they are low voltage.
- T 4. Electrical inspectors do not always inspect communications wiring.
- T 5. Cable ties must not be so tight as to distort the jacket of the cable.

Multiple Choice

Identify the choice that best completes the statement or answers the question.

- A 6. To maintain rated performance, twists in each pair must be maintained to within _____ of the termination.
- A. 1/2 inch
 - B. 1 inch
 - C. 25 mm
 - D. 2.5 cm
- C 7. UTP cable is designed to be pulled with no more than _____ pounds tension.
- A. 5
 - B. 15
 - C. 25
 - D. 50
- B 8. Supports for UTP cables should be _____.
- A. Mounted on walls, not ceilings
 - B. Wide enough to support cables without distortion
 - C. Able to support deep bundles of cables
 - D. Made of plastic for safety
- A 9. _____ should be used to bundle cables since _____.
- A. Hook and loop cable ties, tight cable ties can affect cable performance
 - B. Cable ties tightened with guns, cables should not be allowed to move around
 - C. Cable ties, loose cables are a safety hazard
 - D. Rubber bands, the stretch

__C__

10. Most _____ are designed to allow easy pulling.

- A. Cables
- B. Cable trays
- C. Cable boxes
- D. Ropes

__A__

11. You can keep track of how much cable is left in a box if you _____.

- A. Record on the cable box the beginning distance marked on the cable
- B. Read the distance off the cable
- C. Weigh the box
- D. You can't